

HOUSING SPECIFICATION DRAWING

UNCONTROLLED COPY

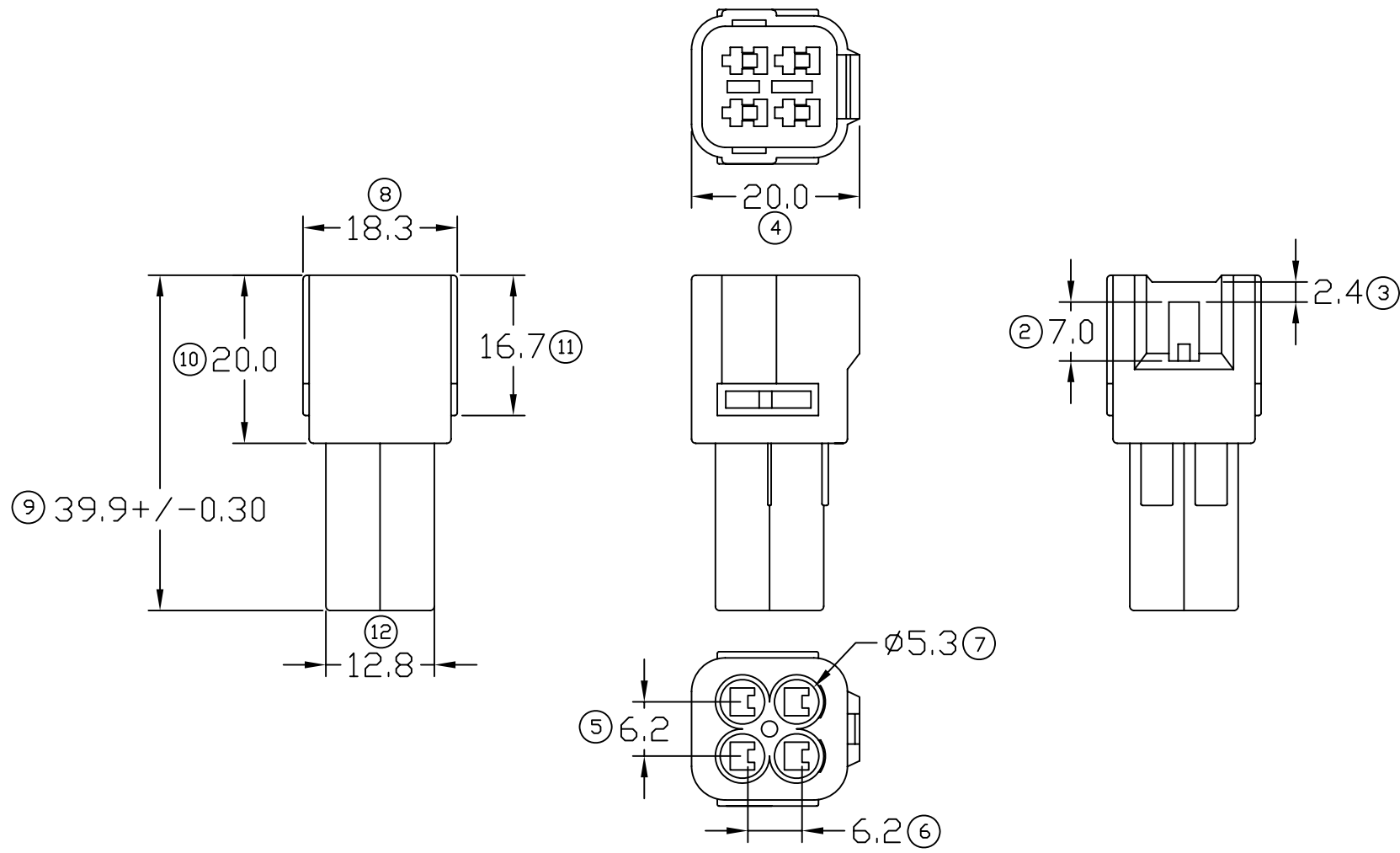

1) PACKING QTY: 400 PCS/BAG

SPECIFICATION :

FOR REFERENCE ONLY

DIMENSIONS : MM TOLERANCE UNLESS OTHERWISE SPECIFIED: X.XXX +/-0.05 X.XX +/-0.10 X.X +/-0.20 X +/-0.50	DWN: KS YEW	EPI Terminals & Connectors Elamp Precision Industry(M) Sdn.Bhd. PART NAME: 090 SERIES CONNECTOR (water proof) APPLICABLE (1) TERMINALS (2) HOUSING (1) 27091M (2) S90-4FSL
	CHK: C.Y CHUANG	
	APVD: Y.L CHUANG	
	SCALE : FREE	
	DRAWING NO: A1257-1	
	EFFECTIVE DATE : 18/2/09	

REV.	DATE	AMENDMENT	REVISION:	SHEET OF :
			02	1 / 1
02	18/2/09	FR ⑨ 39.6 CHANGE TO 39.9 +/- 0.30, FR ⑪ 16.6 TO 16.7		