

# SPECIFICATION DRAWING

MASTER COPY

ITEM NO	MATERIAL	TREATMENT	QTY/REEL	REEL/CARTON	MATCHING PART(S)
120600S-1	t0.5 STAINLESS STEEL (SUS304)	NONE	2000 PCS	7	TERMINAL-N/A HOUSING-N/A

SYMBOL	DESCRIPTION
○	DIMENSION INSPECTED DURING SETUP AND OUTGOING.
□	DIMENSION INSPECTED HOURLY.
SPC	STATISTICALLY CONTROLLED DIMENSION.
△	JIG USED DURING INSPECTION.

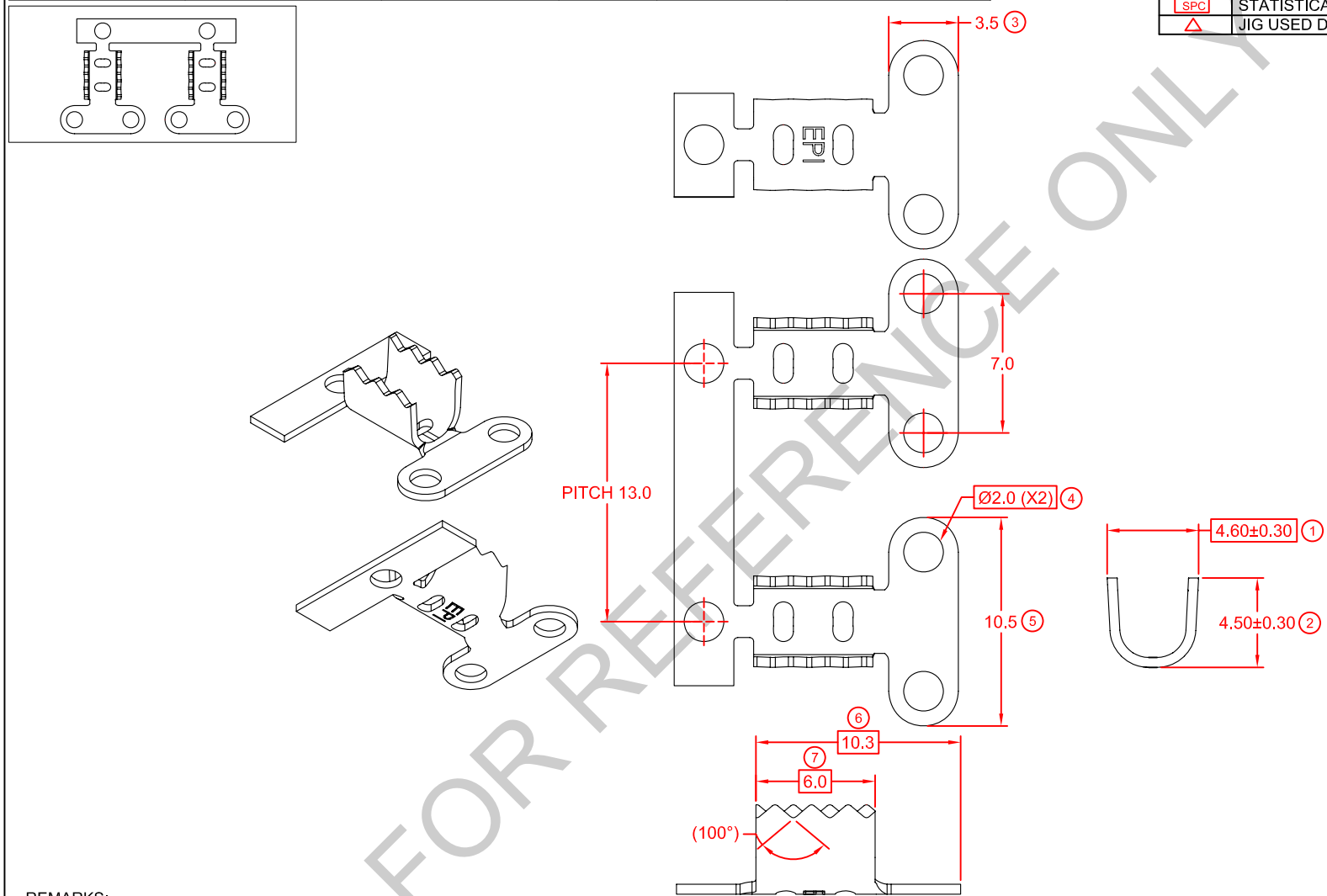

**REMARKS:**

- a) SUGGESTED WIRE INSULATION (O.D): - MM
- b) SUGGESTED WIRE RANGE: 2.71~1.38MM<sup>2</sup> (AWG12~16)

REV.	DATE	AMENDMENT	ECR NO:	REVISION:	GENERAL TOLERANCE UNLESS SPECIFIED:	PREPARE BY:	REVIEWED BY:	
01	29/8/11	UPDATE TO NEW FORMAT	-	01	X.XXX ±0.05 X.XX ±0.10 X.X ±0.20 X ±0.50	KS YEW	CH ANG	
							APPROVED BY: CY CHUANG	
							SCALE : FREE UNIT : MM	
							<b>EP</b> Elamp Precision Industry(M) Sdn.Bhd.	
							ITEM NAME: SPLICE TERMINAL	
							ITEM NO: 120600S-1	
							DRAWING NO: EP-Q-467A	