

SPECIFICATION DRAWING

MASTER COPY

ITEM NO	MATERIAL	TREATMEN	QTY/REEL	REEL/CARTON	MATCHING PART(S)
13860P-1	t0.40 P.BRONZE (C5191)	NONE	1000 PCS	5	TERMINAL-NONE HOUSING-AL882L-GY, AL883-BK, AL882R-OR

SYMBOL	DESCRIPTION
○	DIMENSION INSPECTED DURING SETUP AND OUTGOING.
□	DIMENSION INSPECTED HOURLY.
SPC	STATISTICALLY CONTROLLED DIMENSION.
△	JIG USED DURING INSPECTION.

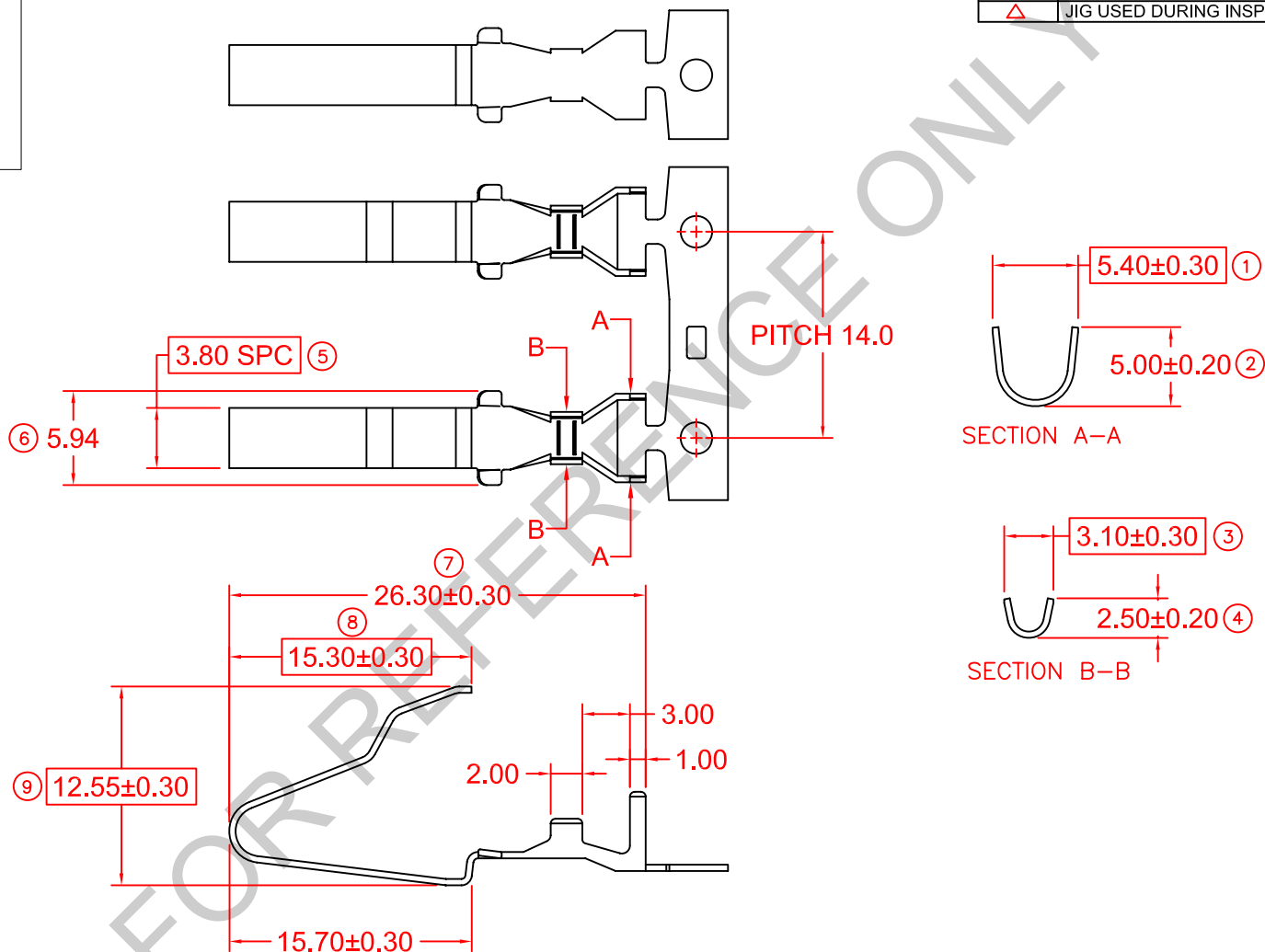
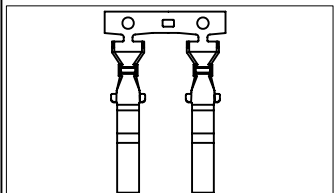

REMARKS:

- a) SUGGESTED WIRE INSULATION (O.D): 3.1MM
- b) SUGGESTED WIRE RANGE: 0.78~0.40MM² (AWG16~20)

				REVISION: 06	GENERAL TOLERANCE UNLESS SPECIFIED: X.XXX ±0.05 X.XX ±0.10 X.X ±0.20 X ±0.50	PREPARE BY: KS YEW	Elamp Precision Industry(M) Sdn.Bhd.
				⊕		REVIEWED BY: CH ANG	
				⊕		APPROVED BY: CY CHUANG	ITEM NO: 13860P-1
06	17/8/11	UPDATE TO NEW FORMAT	-	SHEET OF: 1 / 1	EFFECTIVE DATE: 17/8/11	SCALE : FREE UNIT : MM	DRAWING NO: EP-Q-266A
REV.	DATE	AMENDMENT	ECR NO:				