

SPECIFICATION DRAWING

MASTER COPY

ITEM NO	MATERIAL	TREATMENT	QTY/REEL	REEL/CARTON	MATCHING PART(S)
13861P-1	t0.3 P. BRONZE(C5191)	NONE	3500 PCS	5	TERMINAL-NONE HOUSING-AL882L, AL883, AL882R

SYMBOL	DESCRIPTION
○	DIMENSION INSPECTED DURING SETUP AND OUTGOING.
□	DIMENSION INSPECTED HOURLY.
SPC	STATISTICALLY CONTROLLED DIMENSION.
△	JIG USED DURING INSPECTION.

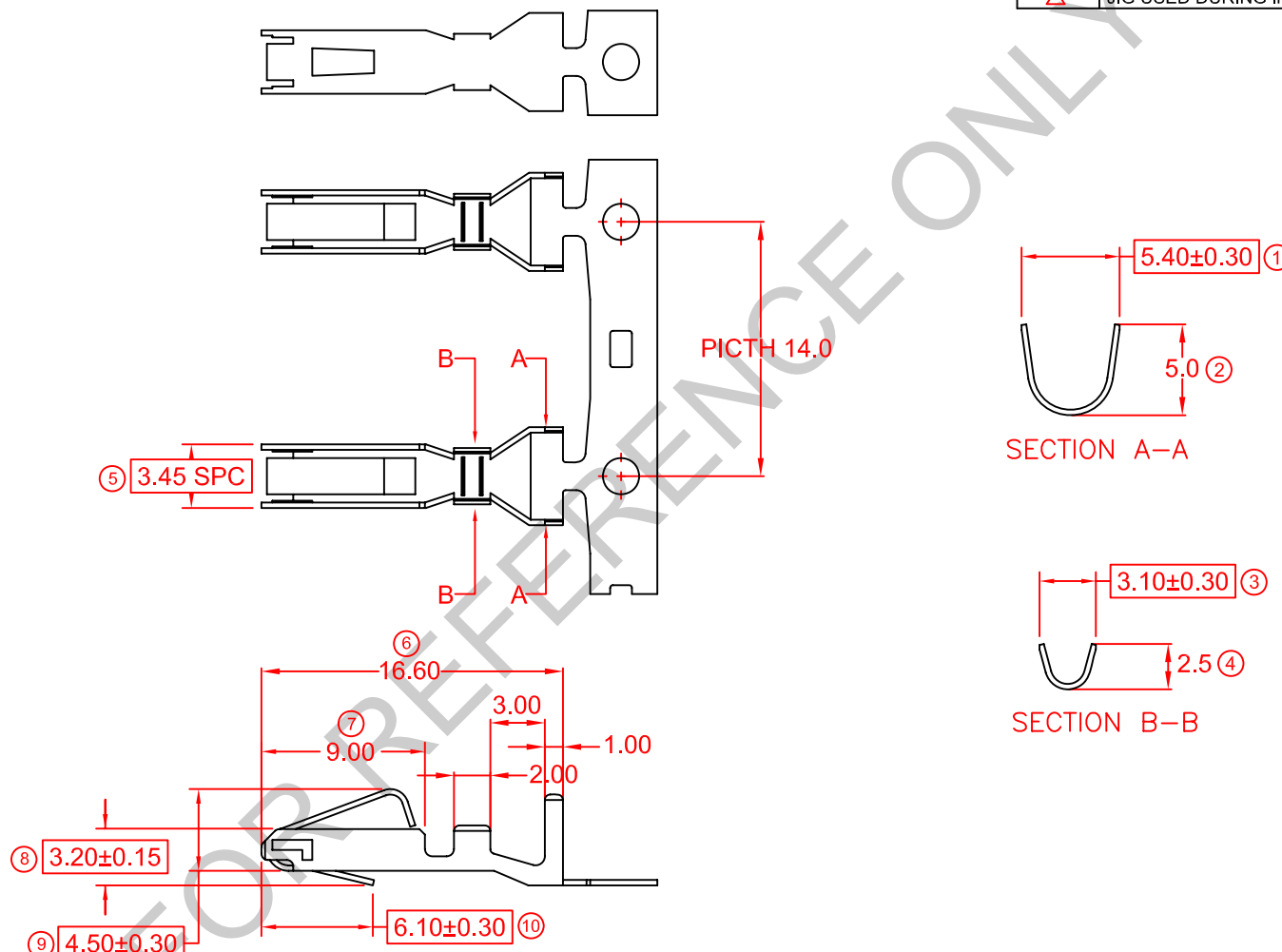
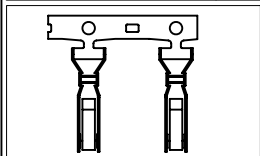

REMARKS:
a) SUGGESTED WIRE INSULATION (O.D): 3.1MM
b) SUGGESTED WIRE RANGE: 0.61~0.27MM² (AWG16~20)

			REVISION: 05		GENERAL TOLERANCE UNLESS SPECIFIED: X.XXX ±0.05 X.XX ±0.10 X.X ±0.20 X ±0.50	PREPARE BY: KS YEW	Elamp Precision Industry(M) Sdn.Bhd.
						REVIEWED BY: CH ANG	
05 19/9/11 UPDATE TO NEW FORMAT			SHEET OF: 1 / 1		EFFECTIVE DATE: 19/9/11	APPROVED BY: CY CHUANG	ITEM NO: 13861P-1
						SCALE : FREE UNIT : MM	DRAWING NO: EP-Q-267A
REV.	DATE	AMENDMENT	ECR NO:				