

TERMINALS SPECIFICATION DRAWING

UNCONTROLLED COPY

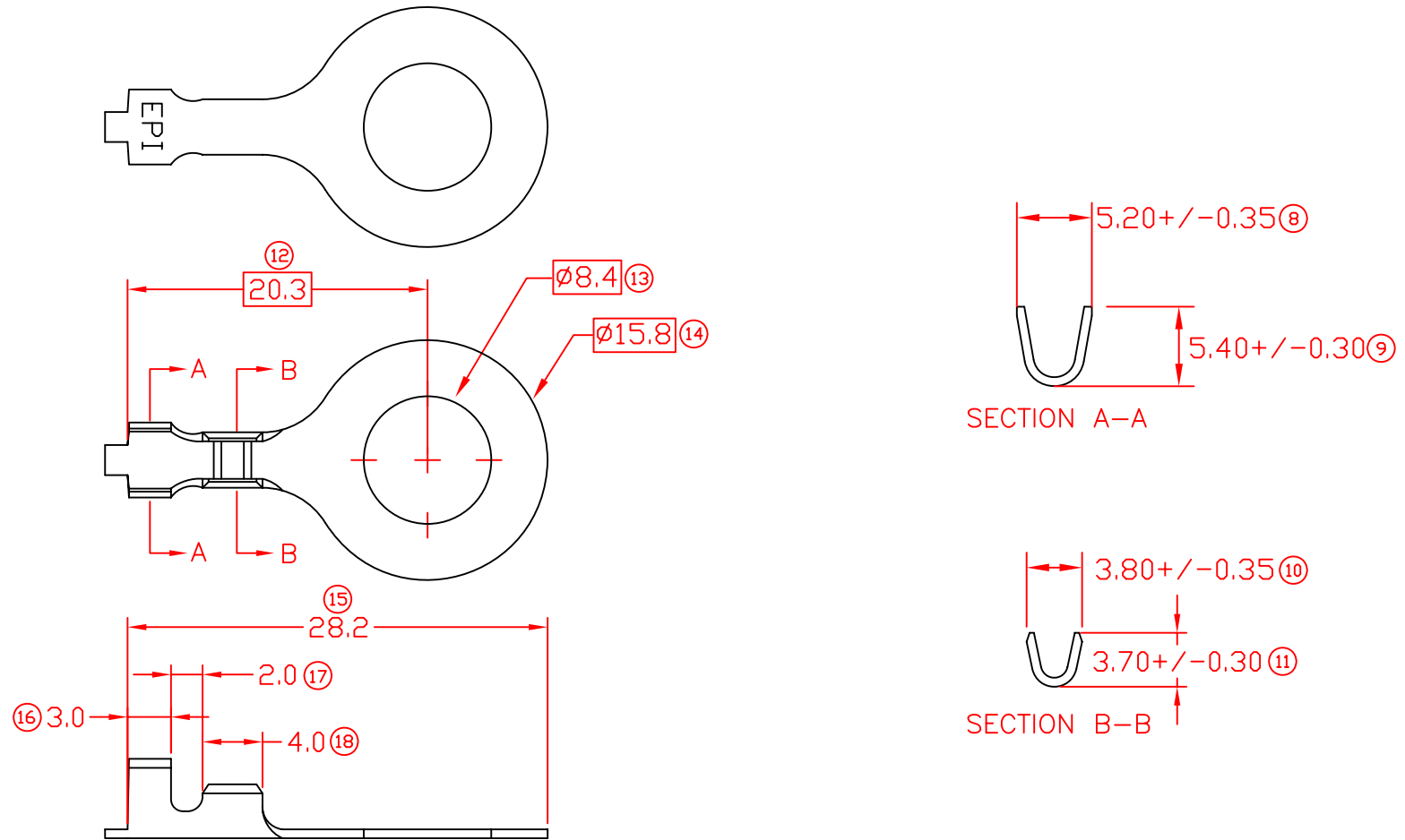

☐ MATCHING DIMENSION

- 7) CRIMPING WIRE TENSILE FORCE IS BASE ON COPPER BREAK OFF INTENSITY.
- 6) TEMPERATURE RANGE -40°C TO $+120^{\circ}\text{C}$.
- 5) VOLTAGE-MAX [VOLTS] PER WIRE SPECIFICATION.
- 4) THICKNESS PLATING MORE THAN 40μ INCH.
- 3) PACKING QTY : 2000 PCS/REEL.
- 2) WIRE INSULATION (O.D) : 3.0MM.
- 1) APPLICABLE WIRE RANGE : 1.52-0.78MM².

FOR REFERENCE ONLY

SPECIFICATION :

| | | |
|------|----------|-------------------------|
| | | |
| 02 | 29/12/10 | UPDATE PACKING QTY ONLY |
| REV. | DATE | AMENDMENT |

| |
|---------------------|
| REVISION: 02 |
| |
| SHEET OF : 1 / 1 |

| | | |
|---|--|-------------|
| MATERIAL: t0.60 BRASS C2680 | - | - |
| | NONE | 140108-1 |
| DIMENSIONS : MM | TREATMENT SELECTIVE | PART NUMBER |
| TOLERANCE UNLESS OTHERWISE SPECIFIED: | PREPARE BY: KS YEW REVIEWED BY: CH ANG APPROVED BY: CY CHUANG SCALE : FREE DRAWING NO: A1471 | |
| X.XXX ± 0.05 X.XX ± 0.10 X.X ± 0.20 X ± 0.50 | EPI Terminals & Connectors Elamp Precision Industry(M) Sdn.Bhd. PART NAME: RING TONGUE TERMINALS APPLICABLE (1) TERMINALS (2) HOUSING (1) - (2) - | |
| EFFECTIVE DATE : 29/12/10 | | |