

TERMINALS SPECIFICATION DRAWING

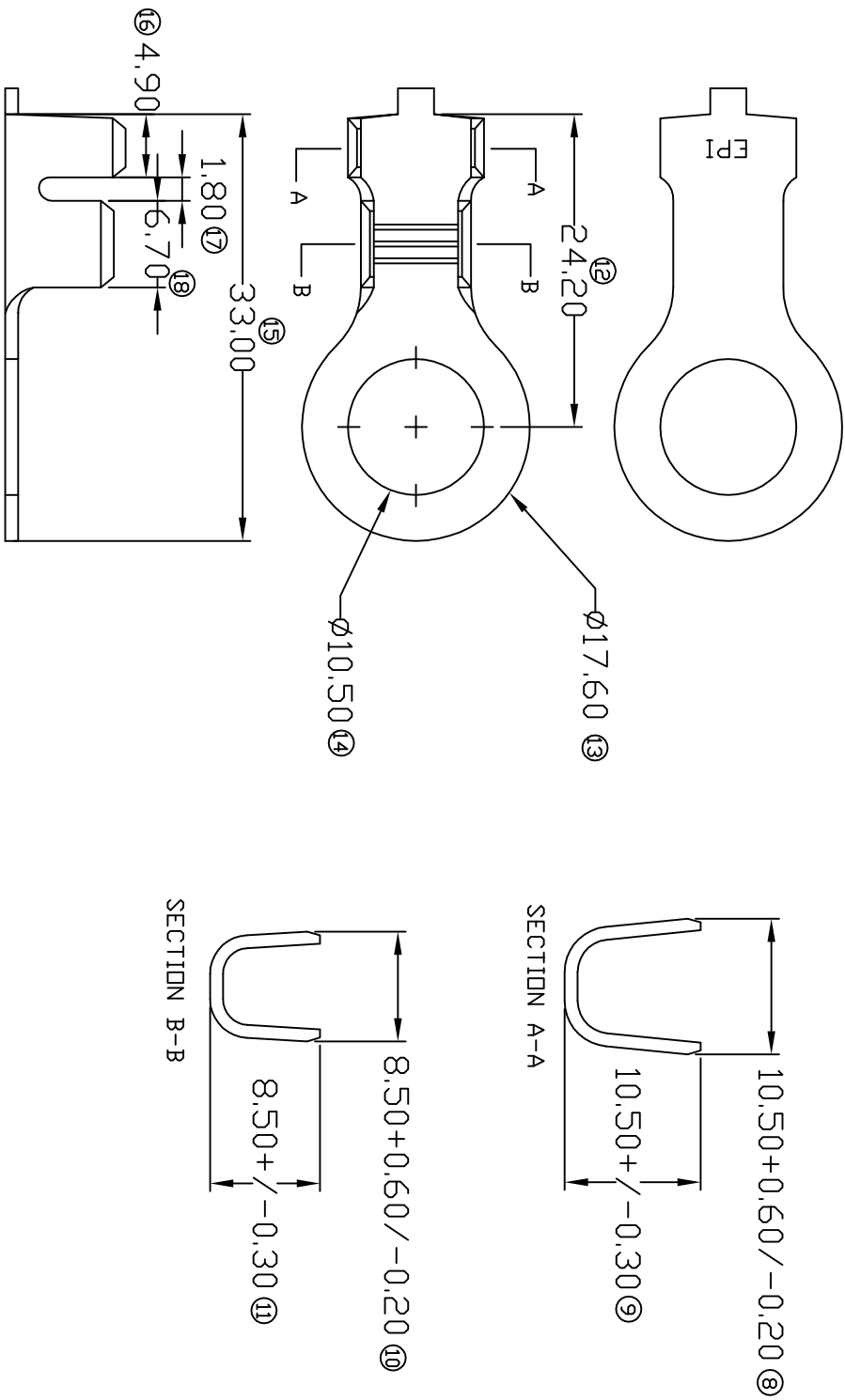

FOR REFERENCE ONLY

- 7) CRIMPING WIRE TENSILE FORCE IS BASE ON COPPER BREAK OFF INTENSITY.
- 6) TEMPERATURE RANGE -40°C TO +120°C.
- 5) VOLTAGE-MAX (VOLTS) PER WIRE SPECIFICATION.
- 4) THICKNESS PLATING MORE THAN 40µ INCH.
- 3) PACKING QTY : - PCS/REEL.
- 2) WIRE INSULATION (OD) : 56MM.
- 1) APPLICABLE WIRE RANGE : 9.15-4.67MM².

SPECIFICATION :

	REVISION: 00		EFFECTIVE DATE : 4/7/07		SHEET OF : 1 / 1
MATERIAL: t1.00 BRASS C2680		PRE-TIN PLATED NONE		1401710-2T 1401710-1	
DIMENSIONS : MM		TREATMENT SELECTIVE		PART NUMBER	
TOLERANCE UNLESS OTHERWISE SPECIFIED:		DWN: KS YE'W		PART NAME: Eiamp Precision Industry(M) Sdn.Bhd.	
X.XXX +/-0.05		CHK: SC CHOO		Terminals & Connectors	
X.XX +/-0.10		APVD: CHUANG		Elamp Precision Industry(M) Sdn.Bhd.	
X.X +/-0.20		SCALE : FREE		RING TONGE TERMINALS	
X +/-0.50		DRAWING NO: A1492		PART NAME: RING TONGE TERMINALS	
				APPLICABLE (1) TERMINALS (2) HOUSING	
				(1) -	
				(2) -	