

SPECIFICATION DRAWING

MASTER COPY

ITEM NO	MATERIAL	TREATMENT	QTY/REEL	REEL/CARTON	MATCHING PART(S)
140743-1	t0.5 BRASS (C2680)	NONE	8000 PCS	4	TERMINAL-N/A
140743-2	t0.5 BRASS (C2680)	TIN PLATING	8000 PCS	4	HOUSING-N/A

SYMBOL	DESCRIPTION
○	DIMENSION INSPECTED DURING SETUP AND OUTGOING.
□	DIMENSION INSPECTED HOURLY.
SPC	STATISTICALLY CONTROLLED DIMENSION.
△	JIG USED DURING INSPECTION.

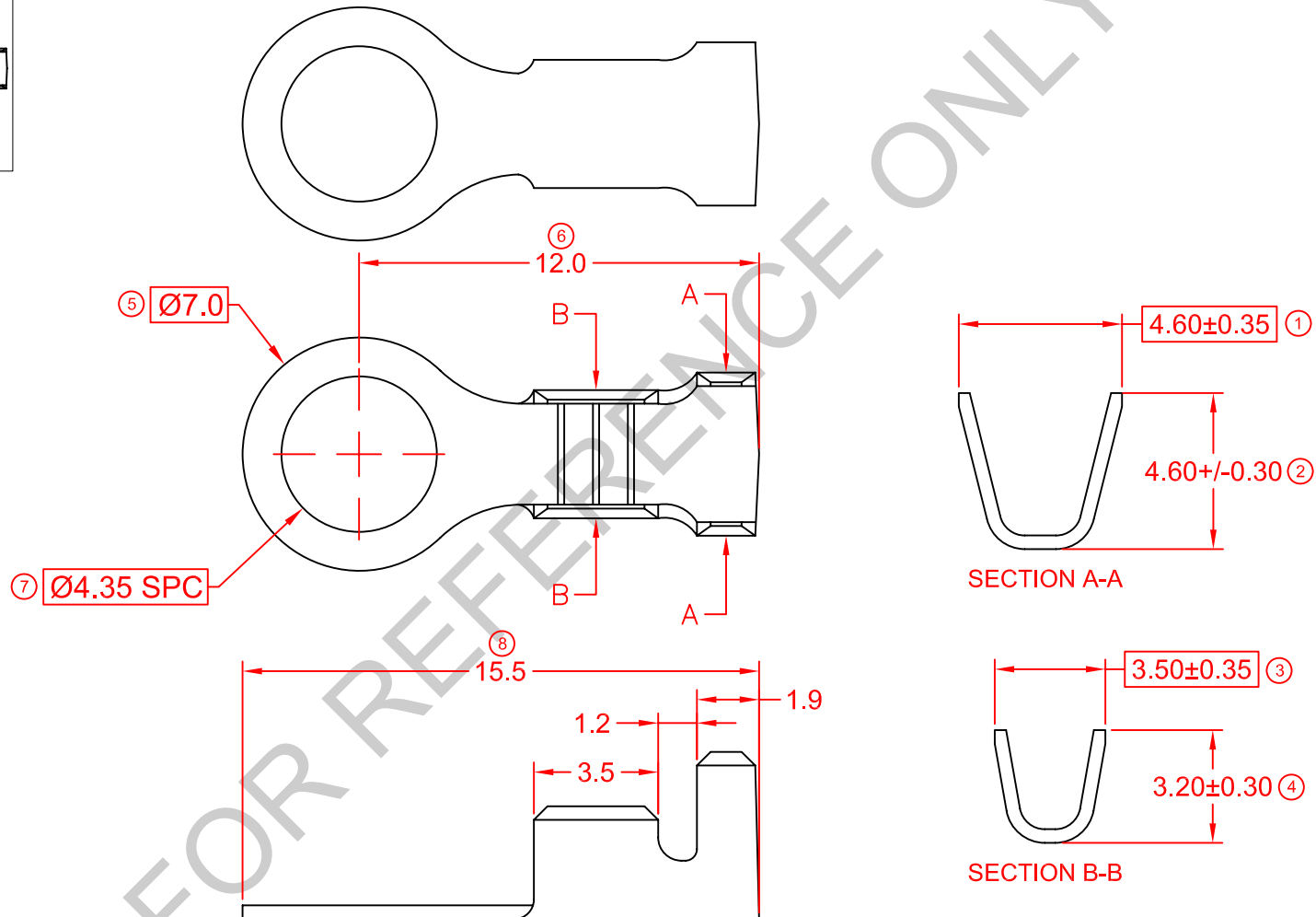
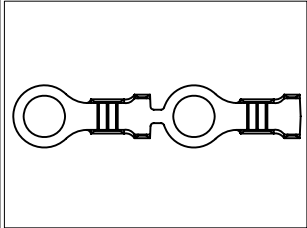

REMARKS:

- a) PLATING THICKNESS MIN 40μ INCH
- b) SUGGESTED WIRE INSULATION (O.D): 2.5MM
- c) SUGGESTED WIRE RANGE: 1.12~0.57MM² (AWG14~18)

				REVISION: 05	GENERAL TOLERANCE UNLESS SPECIFIED: X.XXX ±0.05 X.XX ±0.10 X.X ±0.20 X ±0.50	PREPARE BY: KS YEW	Elamp Precision Industry(M) Sdn.Bhd.	
						REVIEWED BY: CH ANG		ITEM NAME: RING TONGUE TERMINAL
					EFFECTIVE DATE: 18/8/11	APPROVED BY: CY CHUANG	ITEM NO: 140743-1, 2	
05	18/8/11	UPDATE TO NEW FORMAT	-	SHEET OF: 1 / 1		SCALE : FREE	UNIT : MM	DRAWING NO: EP-Q-62A
REV.	DATE	AMENDMENT	ECR NO:					