

# SPECIFICATION DRAWING

MASTER COPY

ITEM NO	MATERIAL	TREATMENT	QTY/REEL	REEL/CARTON	MATCHING PART(S)
141064A-1	t0.5 BRASS (C2680)	NONE	5000 PCS	4	TERMINAL-N/A
141064A-2	t0.5 BRASS (C2680)	TIN PLATING	5000 PCS	4	HOUSING-N/A

SYMBOL	DESCRIPTION
○	DIMENSION INSPECTED DURING SETUP AND OUTGOING.
□	DIMENSION INSPECTED HOURLY.
SPC	STATISTICALLY CONTROLLED DIMENSION.
△	JIG USED DURING INSPECTION.

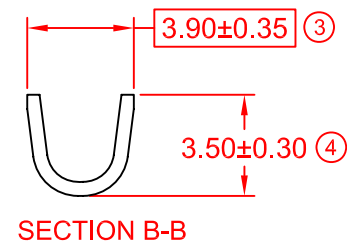
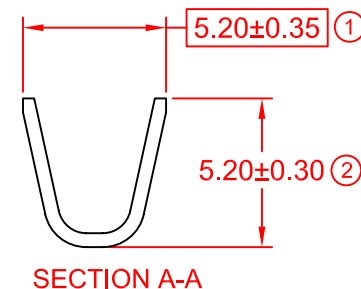
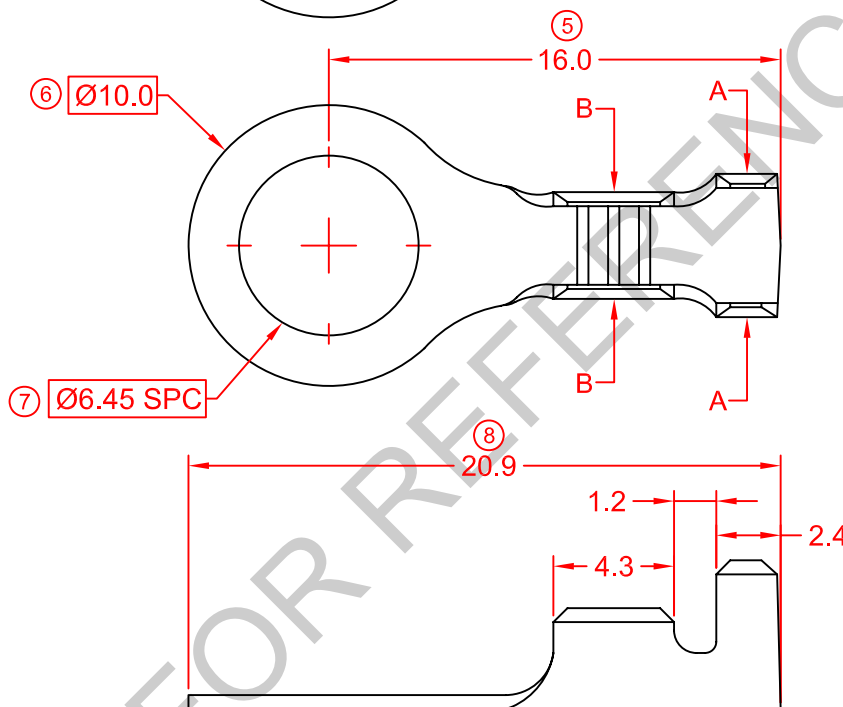
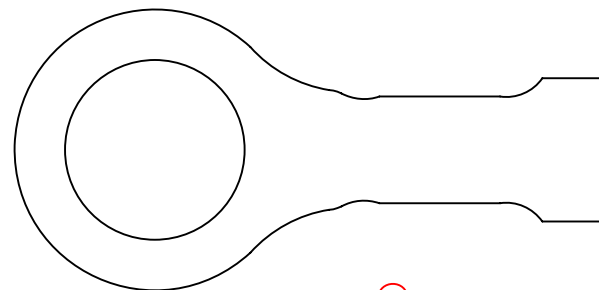
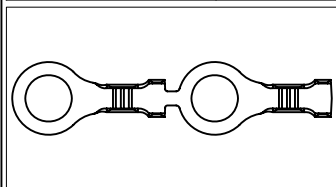

**REMARKS:**

- a) PLATING THICKNESS MIN 40μ INCH
- b) SUGGESTED WIRE INSULATION (O.D): 3.0MM
- c) SUGGESTED WIRE RANGE: 1.51~0.77MM<sup>2</sup> (AWG14~18)

				REVISION: 06	GENERAL TOLERANCE UNLESS SPECIFIED: X.XXX ±0.05 X.XX ±0.10 X.X ±0.20 X ±0.50	PREPARE BY: KS YEW	Elamp Precision Industry(M) Sdn.Bhd.
						REVIEWED BY: CH ANG	
				SHEET OF: 1 / 1	EFFECTIVE DATE: 24/11/11	APPROVED BY: CY CHUANG	ITEM NO: 141064A-1, 2
06	24/11/11	UPDATE TO NEW FORMAT	-	ECR NO:	SCALE : FREE	UNIT : MM	DRAWING NO: EP-Q-18A
REV.	DATE	AMENDMENT					