

SPECIFICATION DRAWING

MASTER COPY

ITEM NO	MATERIAL	TREATMENT	QTY/REEL	REEL/CARTON	MATCHING PART(S)
141264A-1	t0.8 BRASS (C2680)	NONE	2000 PCS	4	TERMINAL-N/A
141264A-2T	t0.8 BRASS (C2680)	PRE-TIN PLATED	2000 PCS	4	HOUSING-N/A

SYMBOL	DESCRIPTION
○	DIMENSION INSPECTED DURING SETUP AND OUTGOING.
□	DIMENSION INSPECTED HOURLY.
SPC	STATISTICALLY CONTROLLED DIMENSION.
△	JIG USED DURING INSPECTION.

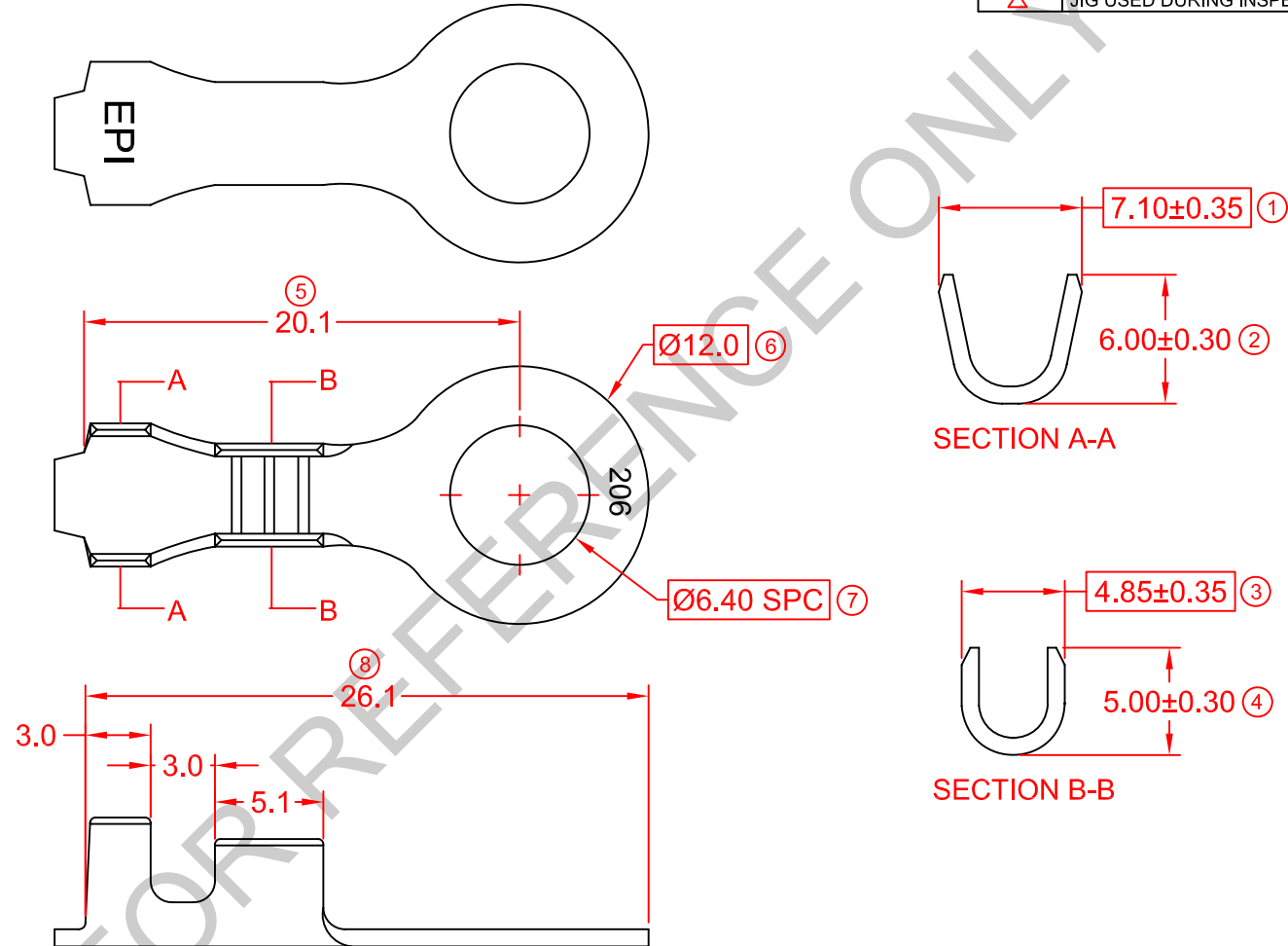

REMARKS:

- a) PLATING THICKNESS MIN 40μ INCH
- b) SUGGESTED WIRE INSULATION (O.D): 3.4MM
- c) SUGGESTED WIRE RANGE: 2.70~1.38MM² (AWG12~16)

			REVISION: 03		GENERAL TOLERANCE UNLESS SPECIFIED: X.XXX ±0.05 X.XX ±0.10 X.X ±0.20 X ±0.50	PREPARE BY: KS YEW		Elamp Precision Industry(M) Sdn.Bhd.
			SHEET OF: 1 / 1			REVIEWED BY: CH ANG		
			EFFECTIVE DATE: 20/12/11		APPROVED BY: CY CHUANG		ITEM NO: 141264A-1, 2T	
03	20/12/11	UPDATE TO NEW FORMAT			SCALE : FREE		DRAWING NO: EP-Q-382A	
REV.	DATE	AMENDMENT	ECR NO:		UNIT : MM			