

# SPECIFICATION DRAWING

MASTER COPY

| ITEM NO   | MATERIAL            | TREATMENT   | QTY/REEL | REEL/CARTON | MATCHING PART(S)         |
|-----------|---------------------|-------------|----------|-------------|--------------------------|
| 17110HA-1 | t0.25 BRASS (C2680) | NONE        | 10000PCS | 4           | TERMINAL-TAB t0.5 X W2.8 |
| 17110HA-2 | t0.25 BRASS (C2680) | TIN PLATING | 10000PCS | 4           | HOUSING-N/A              |

| SYMBOL | DESCRIPTION                                    |
|--------|--|
| ○      | DIMENSION INSPECTED DURING SETUP AND OUTGOING. |
| □      | DIMENSION INSPECTED HOURLY.                    |
| SPC    | STATISTICALLY CONTROLLED DIMENSION.            |
| △      | JIG USED DURING INSPECTION.                    |

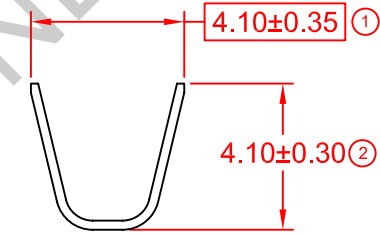
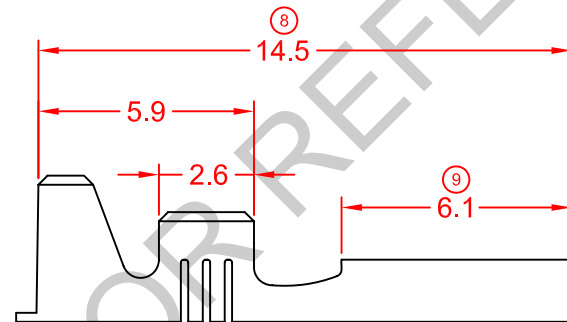
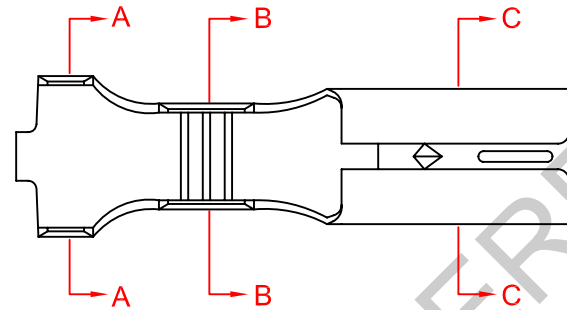
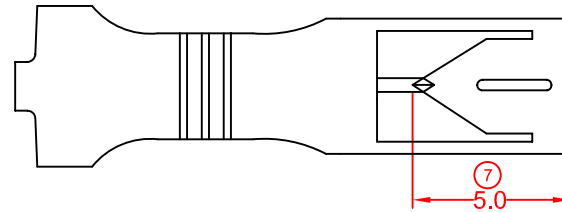
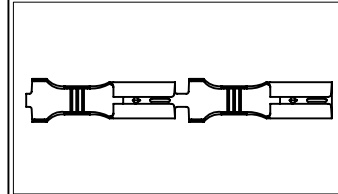

SECTION A-A

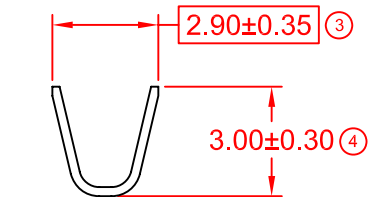

SECTION B-B

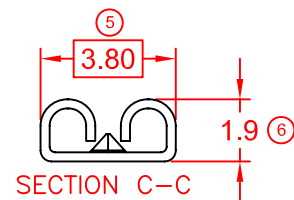

SECTION C-C

**REMARKS:**

- a) PLATING THICKNESS MIN 40μ INCH
- b) SUGGESTED WIRE INSULATION (O.D): 2.5MM
- c) SUGGESTED WIRE RANGE: 0.77~0.34MM<sup>2</sup> (AWG16~20)
- d) INSERT FORCE: MAX 2.10KG
- e) TENSILE FORCE: MIN 4.00KG

|      |         |                      |         |                    |  |                           |                                      |
|------|---------|----------------------|---------|--------------------|--|---------------------------|--------------------------------------|
|      |         |                      |         | REVISION:<br>04    | GENERAL TOLERANCE UNLESS SPECIFIED:<br>X.XXX ±0.05<br>X.XX ±0.10<br>X.X ±0.20<br>X ±0.50 | PREPARE BY:<br>KS YEW     | Elamp Precision Industry(M) Sdn.Bhd. |
|      |         |                      |         |                    |  | REVIEWED BY:<br>CH ANG    |                                      |
|      |         |                      |         |                    | EFFECTIVE DATE:<br>12/9/11   | APPROVED BY:<br>CY CHUANG | ITEM NO: 17110HA-1, 2                |
| 04   | 12/9/11 | UPDATE TO NEW FORMAT | -       | SHEET OF:<br>1 / 1 |  | SCALE : FREE              | DRAWING NO: EP-Q-1A                  |
| REV. | DATE    | AMENDMENT            | ECR NO: |                    | UNIT : MM  |                           |                                      |