

# SPECIFICATION DRAWING

MASTER COPY

ITEM NO	MATERIAL	TREATMENT	QTY/REEL	REEL/CARTON	MATCHING PART(S)
27093S-2T	t0.3 BRASS (C2680)	PRE-TIN PLATED	4000 PCS	5	TERMINAL-N/A HOUSING-AL053

SYMBOL	DESCRIPTION
○	DIMENSION INSPECTED DURING SETUP AND OUTGOING.
□	DIMENSION INSPECTED HOURLY.
SPC	STATISTICALLY CONTROLLED DIMENSION.
△	JIG USED DURING INSPECTION.

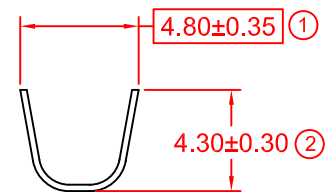
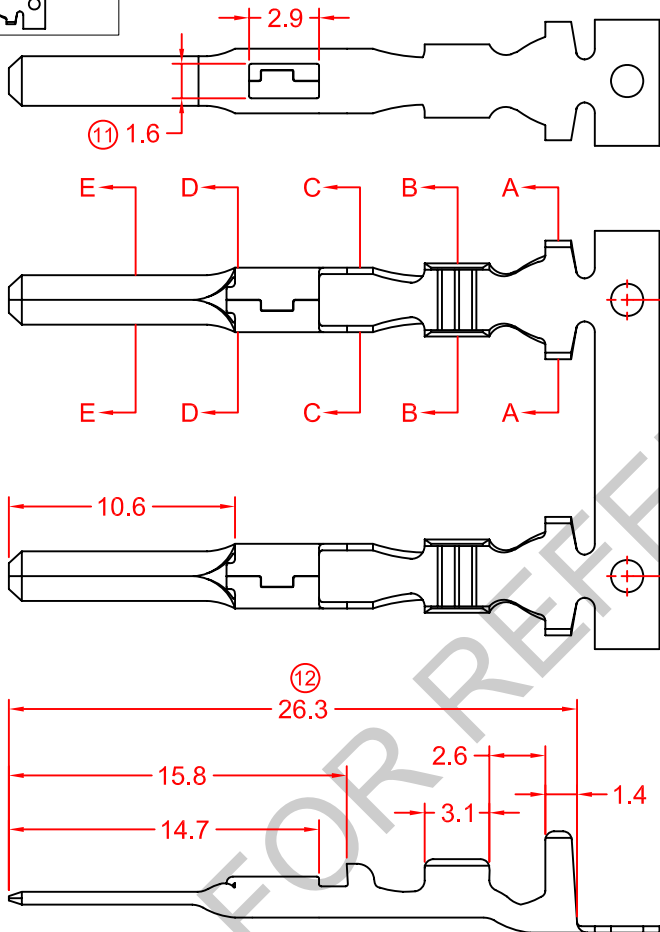
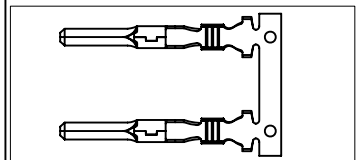

SECTION A-A

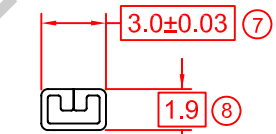

SECTION D-D

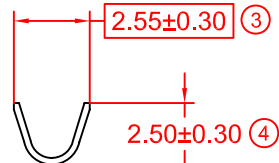

SECTION B-B

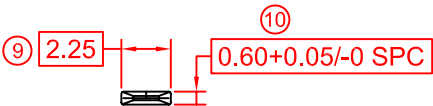

SECTION E-E

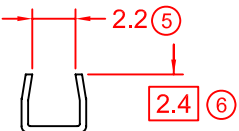

SECTION C-C

**REMARKS:**

- a) PLATING THICKNESS MIN 40μ INCH
- b) SUGGESTED WIRE INSULATION (O.D): 2.6MM
- c) SUGGESTED WIRE RANGE: 0.55~0.23MM<sup>2</sup> (AWG18~22)

				REVISION: 05	GENERAL TOLERANCE UNLESS SPECIFIED: X.XXX ±0.05 X.XX ±0.10 X.X ±0.20 X ±0.50	PREPARE BY: KS YEW	Elamp Precision Industry(M) Sdn.Bhd.
				⊕		REVIEWED BY: CH ANG	
05	19/1/12	(7) 3.0±0.20 CHANGE TO 3.0±0.03	12-01-04	⊕		APPROVED BY: CY CHUANG	ITEM NAME: 090 SERIES TAB
04	10/10/11	UPDATE TO NEW FORMAT	-	SHEET OF: 1 / 1	EFFECTIVE DATE: 19/1/12	SCALE : FREE UNIT : MM	ITEM NO: 27093S-2T
REV.	DATE	AMENDMENT	ECR NO:				DRAWING NO: EP-Q-127A