

# SPECIFICATION DRAWING

MASTER COPY

ITEM NO	MATERIAL	TREATMENT	QTY/REEL	REEL/CARTON	MATCHING PART(S)
27096M-2T	t0.3 BRASS (C2680)	PRE-TIN PLATED	4000 PCS	4	TERMINAL-17096 HOUSING-090 SERIES

SYMBOL	DESCRIPTION
○	DIMENSION INSPECTED DURING SETUP AND OUTGOING.
□	DIMENSION INSPECTED HOURLY.
SPC	STATISTICALLY CONTROLLED DIMENSION.
△	JIG USED DURING INSPECTION.

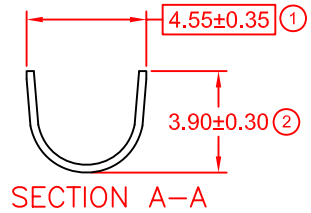
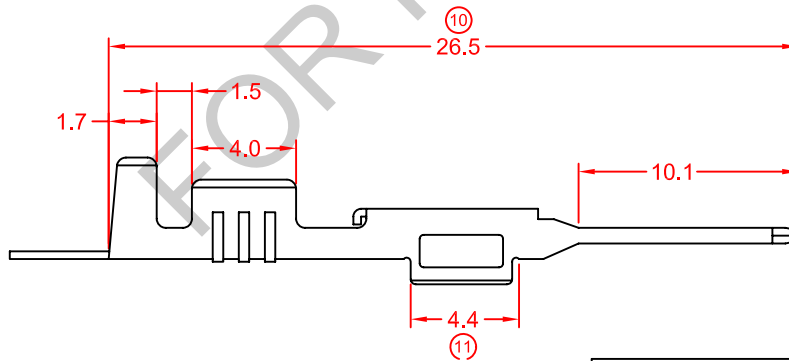
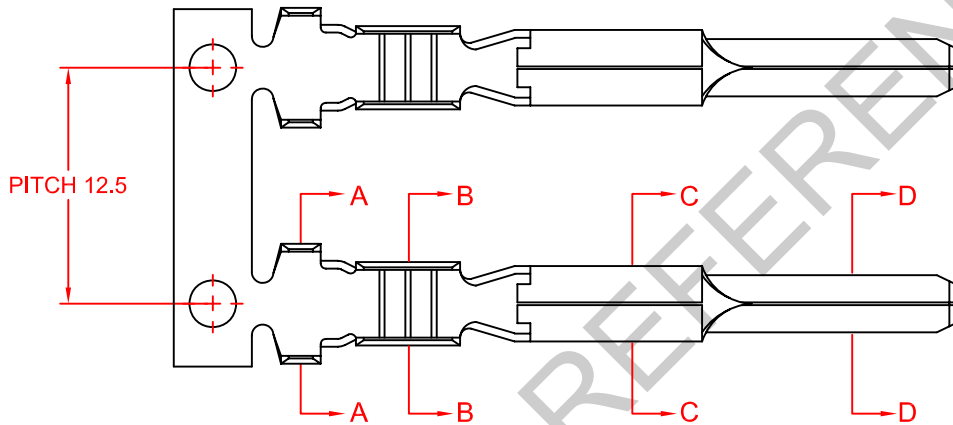
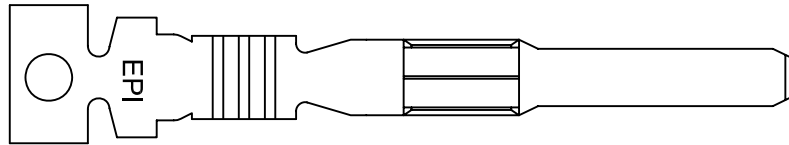
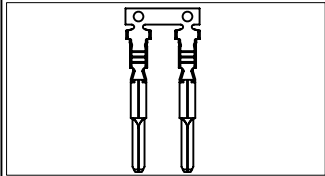

SECTION A-A

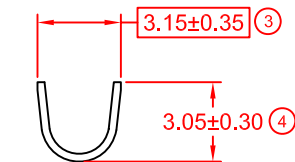

SECTION B-B

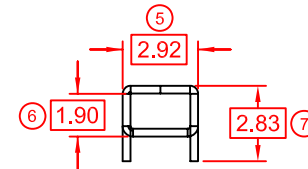

SECTION C-C

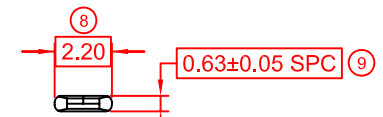

SECTION D-D

**REMARKS:**

- a) PLATING THICKNESS MIN 40μ INCH
- b) SUGGESTED WIRE INSULATION (O.D): 2.3MM
- c) SUGGESTED WIRE RANGE: 0.82~0.36MM<sup>2</sup> (AWG16~20)

GENERAL TOLERANCE  
UNLESS SPECIFIED:

X.XXX	±0.05
X.XX	±0.10
X.X	±0.20
X	±0.50

PREPARE BY:  
KS YEW

REVIEWED BY:  
CH ANG

APPROVED BY:  
CY CHUANG

SCALE : FREE  
UNIT : MM

**EPI** Elamp Precision Industry(M) Sdn.Bhd.

ITEM NAME: 090 SERIES TAB

ITEM NO: 27096M-2T

DRAWING NO: EP-Q-288A

REV.	DATE	AMENDMENT	ECR NO:	REVISION:	SHEET OF:
02	16/8/11	UPDATE TO NEW FORMAT	-	02	1 / 1

REVISION:	SHEET OF:	EFFECTIVE DATE:	SCALE :	UNIT :	ITEM NAME:
02	1 / 1	16/8/11	FREE	MM	090 SERIES TAB
					ITEM NO: 27096M-2T
					DRAWING NO: EP-Q-288A