

# SPECIFICATION DRAWING

MASTER COPY

ITEM NO	MATERIAL	TREATMENT	QTY/REEL	REEL/CARTON	MATCHING PART(S)
272503M-1	t0.4 BRASS (C2680)	NONE	4000 PCS	4	TERMINAL-172503
272503M-2T	t0.4 BRASS (C2680)	PRE-TIN PLATED	4000 PCS	4	HOUSING-250 SERIES

SYMBOL	DESCRIPTION
○	DIMENSION INSPECTED DURING SETUP AND OUTGOING.
□	DIMENSION INSPECTED HOURLY.
SPC	STATISTICALLY CONTROLLED DIMENSION.
△	JIG USED DURING INSPECTION.

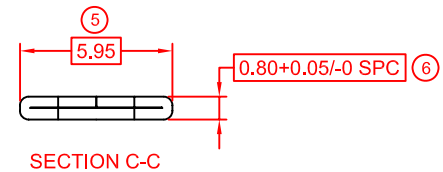
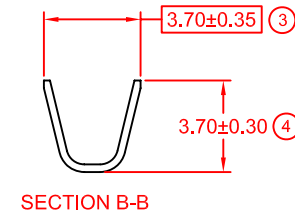
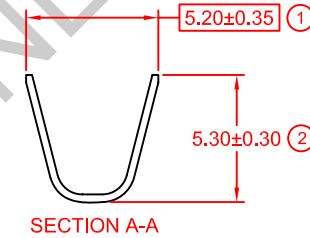
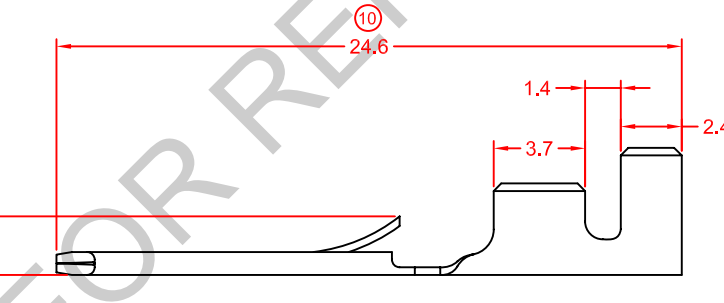
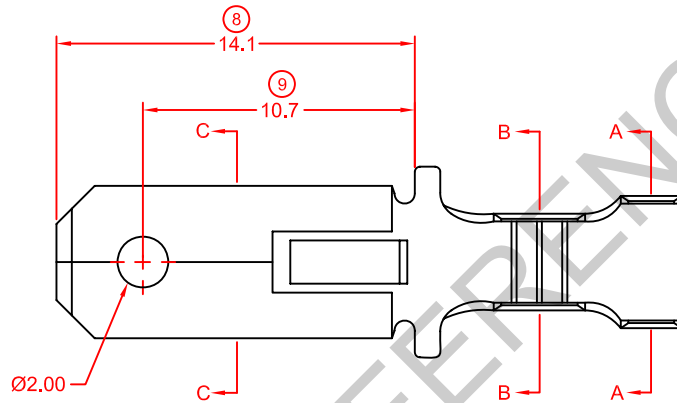
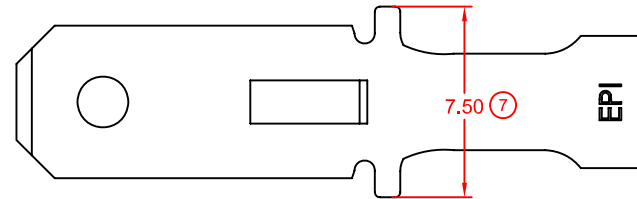
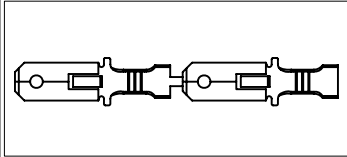

**REMARKS:**

- a) PLATING THICKNESS MIN 40μ INCH
- b) SUGGESTED WIRE INSULATION (O.D): 3.0MM
- c) SUGGESTED WIRE RANGE: 1.64~0.84MM<sup>2</sup> (AWG14~18)

				REVISION: 07	GENERAL TOLERANCE UNLESS SPECIFIED: X.XXX ±0.05 X.XX ±0.10 X.X ±0.20 X ±0.50	PREPARE BY: KS YEW	Elamp Precision Industry(M) Sdn.Bhd.
				SHEET OF: 1 / 1		REVIEWED BY: CH ANG	
07	21/11/11	UPDATE TO NEW FORMAT	-	EFFECTIVE DATE: 21/11/11	APPROVED BY: CY CHUANG	ITEM NO: 272503M-1, 2T	DRAWING NO: EP-Q-28A
REV.	DATE	AMENDMENT	ECR NO:	SCALE : FREE	UNIT : MM		