

SPECIFICATION DRAWING

MASTER COPY

ITEM NO	MATERIAL	TREATMENT	QTY/BAG	BAG/CARTON	MATCHING PART(S)
275052-2	t0.5 BRASS (C2680)	TIN PLATING	2000 PCS	40	TERMINAL-N/A HOUSING-N/A

SYMBOL	DESCRIPTION
○	DIMENSION INSPECTED DURING SETUP AND OUTGOING.
□	DIMENSION INSPECTED HOURLY.
SPC	STATISTICALLY CONTROLLED DIMENSION.
△	JIG USED DURING INSPECTION.

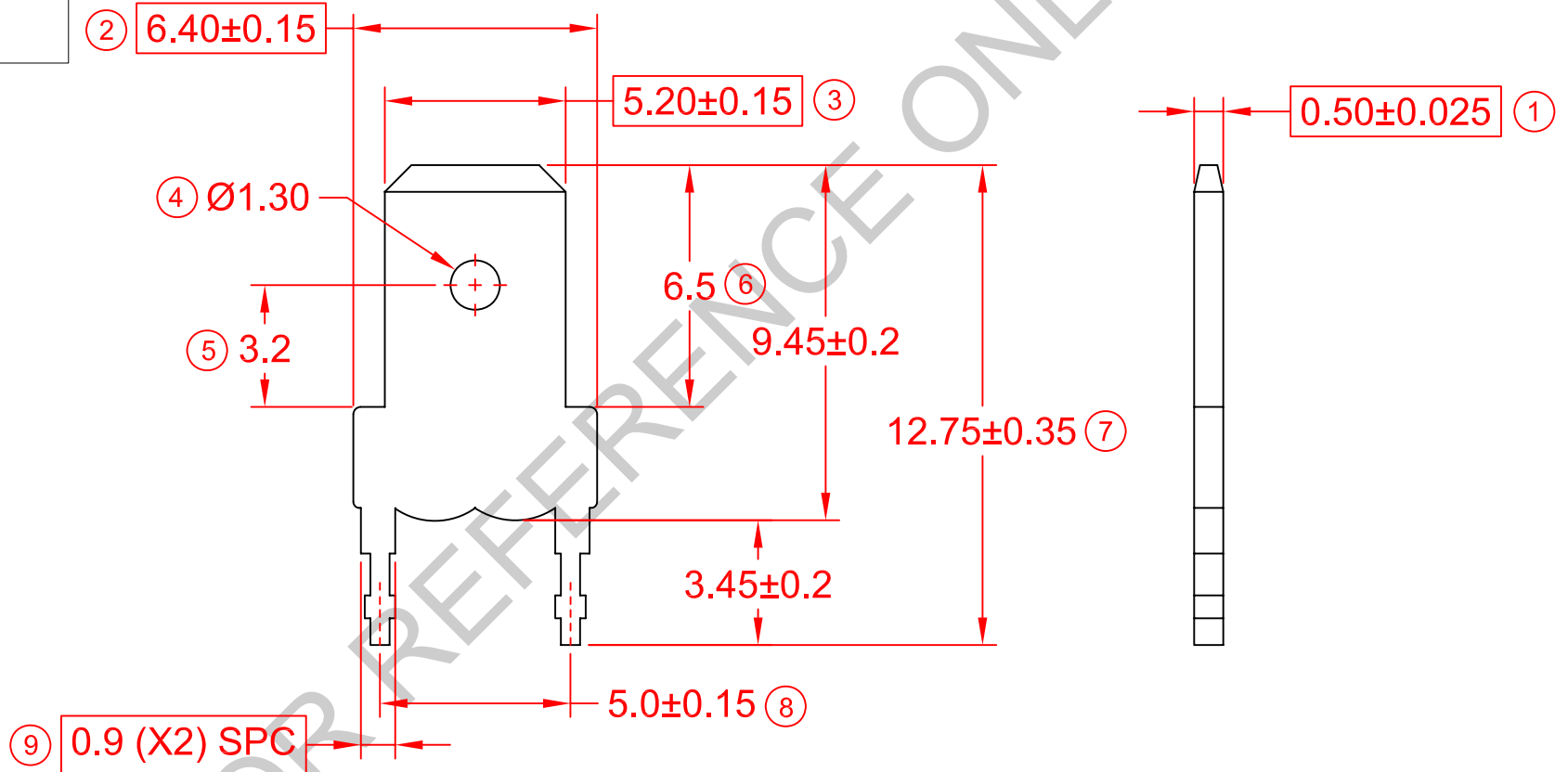
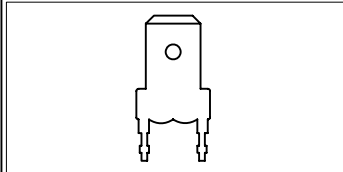

REMARKS:

- a) PLATING THICKNESS MIN 40μ INCH
- b) FOR PC BOARD Ø1.00MM THICKNESS 1.60MM

GENERAL TOLERANCE
UNLESS SPECIFIED:

X.XXX	±0.05
X.XX	±0.10
X.X	±0.20
X	±0.50

PREPARE BY:
KS YEW

REVIEWED BY:
CH ANG

APPROVED BY:
CY CHUANG

EPI Elamp Precision Industry(M) Sdn.Bhd.

ITEM NAME: 205 SERIES TAB TERMINAL

ITEM NO: 275052-2

DRAWING NO: EP-Q-178A

REV.	DATE	AMENDMENT	ECR NO:
04	5/9/11	UPDATE TO NEW FORMAT	-

REVISION: 04	
SHEET OF: 1 / 1	

EFFECTIVE DATE:
5/9/11

SCALE : FREE
UNIT : MM