

# TERMINALS SPECIFICATION DRAWING

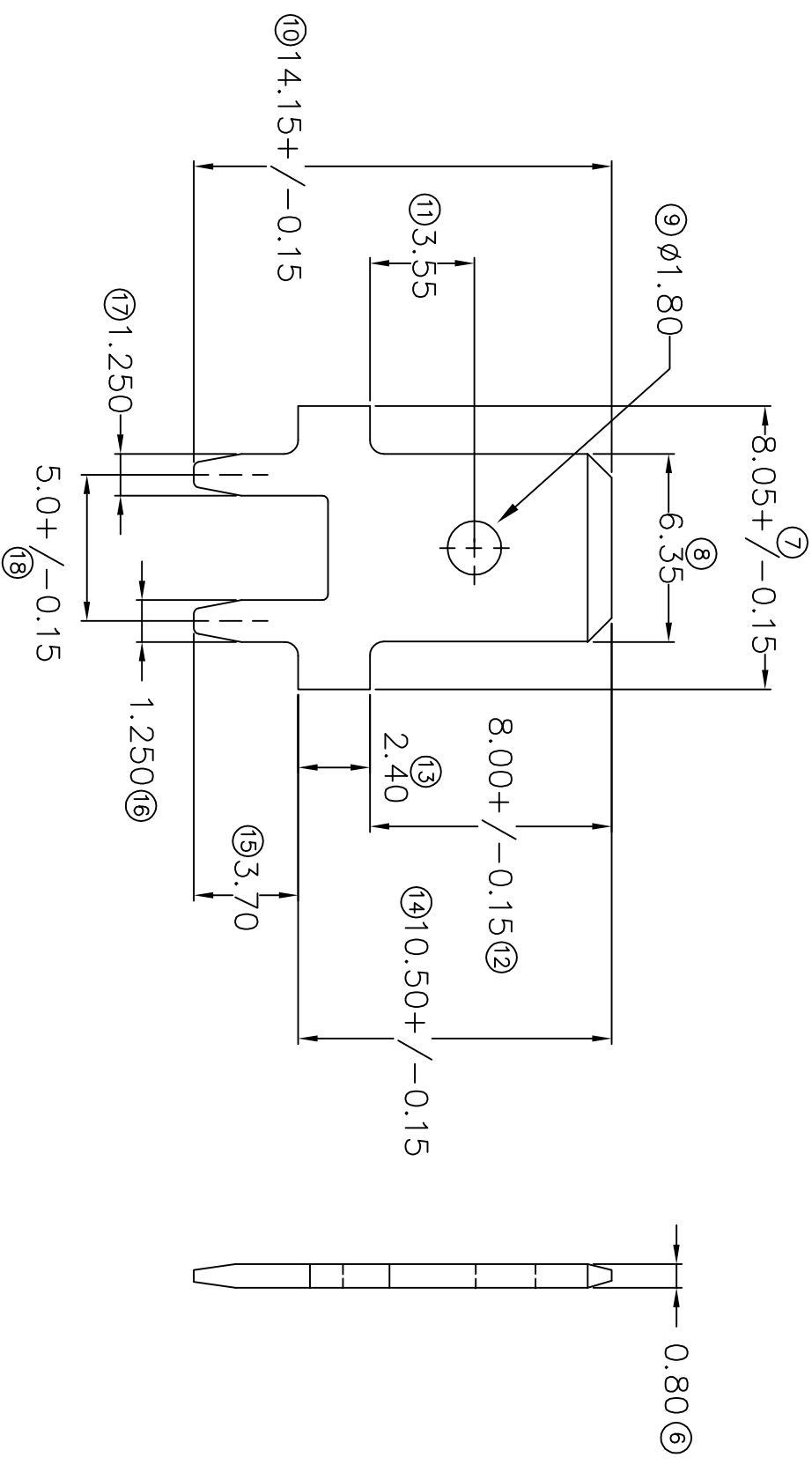

FOR REFERENCE ONLY

- 5) FDR PC BOARD  $\phi$ 1.20MM THICKNESS 1.60MM.
- 4) TEMPERATURE RANGE -40°C TO +120°C.
- 3) VOLTAGE-MAX [VOLTS] PER WIRE SPECIFICATION.
- 2) THICKNESS PLATING MORE THAN 40μ INCH.
- 1) PACKING QTY : 2000 PCS/BAG.

SPECIFICATION :

MATERIAL: t0.80 BRASS C2680	PRE-TIN PLATED TIN PLATING TREATMENT SELECTIVE	278636L-2T 278636L-2 PART NUMBER
DIMENSIONS : MM TOLERANCE UNLESS OTHERWISE SPECIFIED: X.XXX +/-0.05 X.XX +/-0.10 X.X +/-0.20 X +/-0.50	DWN: KS YEW CHK: SC CHOO APVD: CHUANG	EPI Terminals & Connectors Elamp Precision Industry(M) Sdn.Bhd.
EFFECTIVE DATE : 24/7/07	SCALE : FREE DRAWING NO: A1444	PART NAME: 250 TYPE TERMINALS APPLICABLE (1) TERMINALS (2) HOUSING (1) _____ (2) _____
SHEET OF : 1 / 1	REVISION: 04	