

TERMINALS SPECIFICATION DRAWING

UNCONTROLLED COPY

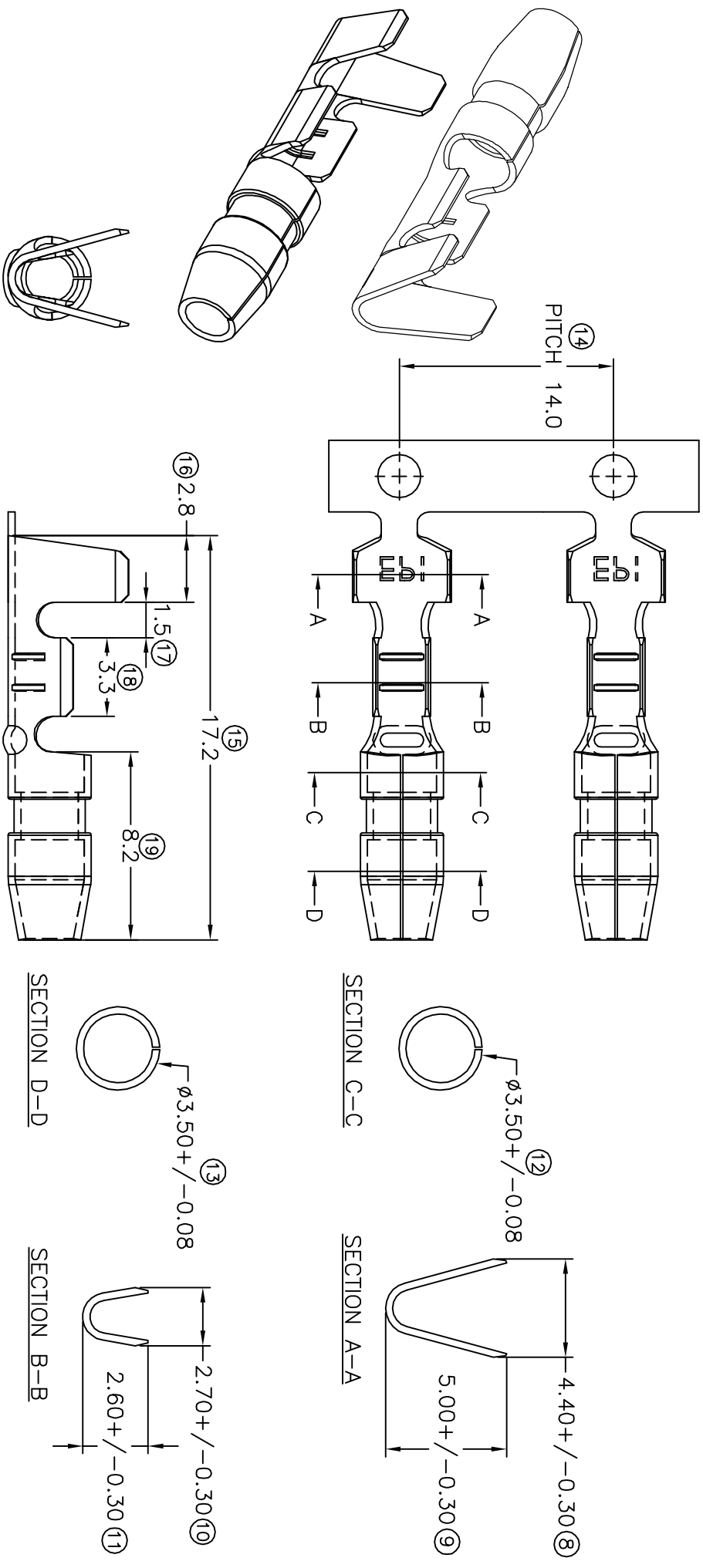

- 7) CRIMPING WIRE TENSILE FORCE IS BASE ON COPPER BREAK OFF INTENSITY.
- 6) TEMPERATURE RANGE -40°C TO +120°C
- 5) VOLTAGE-MAX [VOLTS] PER WIRE SPECIFICATION.
- 4) THICKNESS PLATING MORE THAN 40µ INCH.
- 3) PACKING QTY : 3000 PCS/REEL.
- 2) WIRE INSULATION (O.D) : 2.7MM.
- 1) APPLICABLE WIRE RANGE : 0.57~0.25MM.

SPECIFICATION :

FOR REFERENCE ONLY

00	23/10/08	NEW RELEASE					
REV.	DATE	AMENDMENT	SHEET OF :	EFFECTIVE DATE :		DRAWING NO :	
			1 / 1	23/10/08		A1527	
			REVISION:	TOLERANCE UNLESS OTHERWISE SPECIFIED:			
			00	X.XXX +/-0.05			
				X.XX +/-0.10			
				X.X +/-0.20			
				X +/-0.50			
				DWN: KS YEW			
				TIN PLATING			
				NONE			
				TREATMENT SELECTIVE			
				PART NUMBER			
				28041S-2			
				28041S-1			
				PART NAME:			
				Eiamp Precision Industry(M) Sdn.Bhd.			
				Terminals & Connectors			
				Ø4.00 BULLET TERMINALS			
				APPLICABLE (1) TERMINALS (2) HOUSING			
				(1) 18041			
				(2) -			