

TERMINALS SPECIFICATION DRAWING

UNCONTROLLED COPY

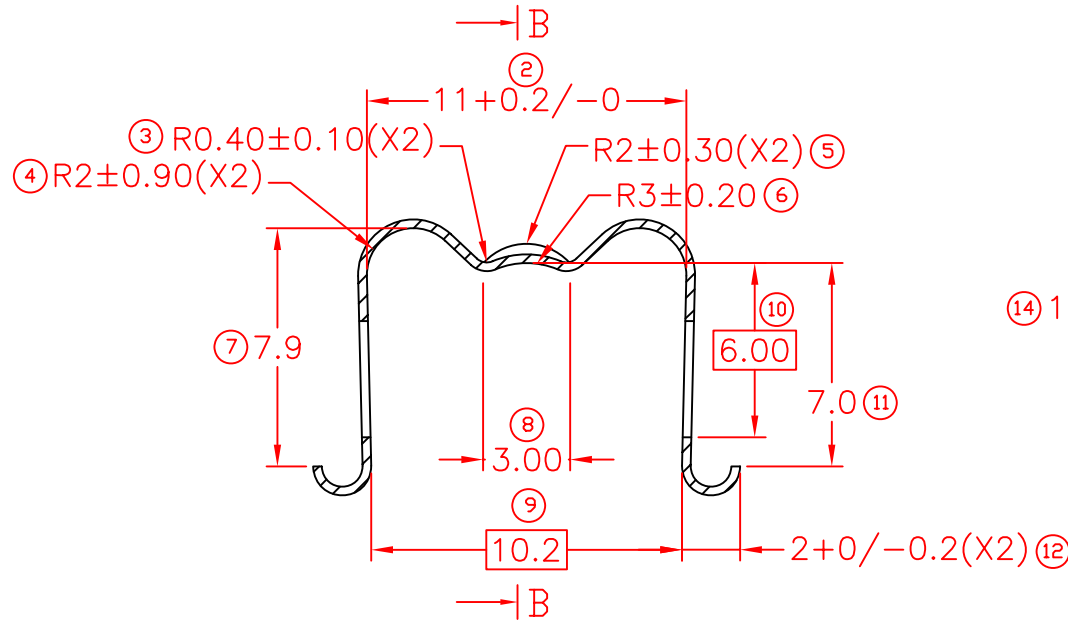

SECTION A-A

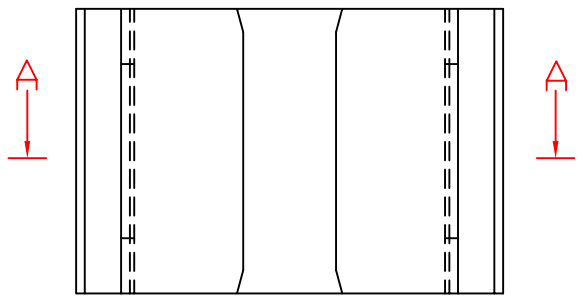
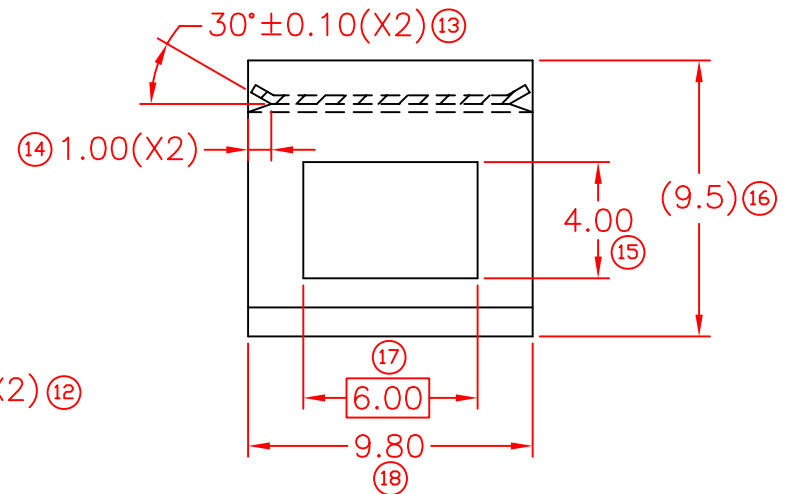

SECTION B-B

☐ MATCHING DIMENSION
 1) PACKING QTY: 2000 PCS/BAG.
SPECIFICATION:

FOR REFERENCE ONLY

REVISION:
00

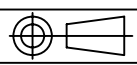

SHEET OF :
1 / 1

MATERIAL:
±0.30 STAINLESS
STEEL
SUS301

DIMENSIONS : MM
 TOLERANCE UNLESS OTHERWISE SPECIFIED:
 X.XXX +/-0.05
 X.XX +/-0.10
 X.X +/-0.20
 X +/-0.50

EFFECTIVE DATE :
15/2/11

	-	-
	NONE	AL082-1
	TREATMENT SELECTIVE	PART NUMBER
DWN: KS YEW	EPI Terminals & Connectors	
CHK: CH ANG	Elamp Precision Industry(M) Sdn.Bhd.	
APVD: CY CHUANG	PART NAME: SPRING CLIP	
SCALE : FREE	APPLICABLE (1) TERMINALS (2) HOUSING	
DRAWING NO: A1580	(1) - (2) F 014 001 466	

00	15/2/11	NEW RELEASE	
TEMP	5/1/11	FOR CUSTOMER APPROVAL PURPOSE	
REV.	DATE	AMENDMENT	