

TERMINALS SPECIFICATION DRAWING

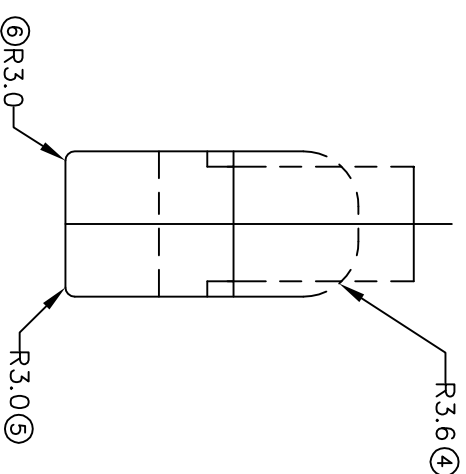
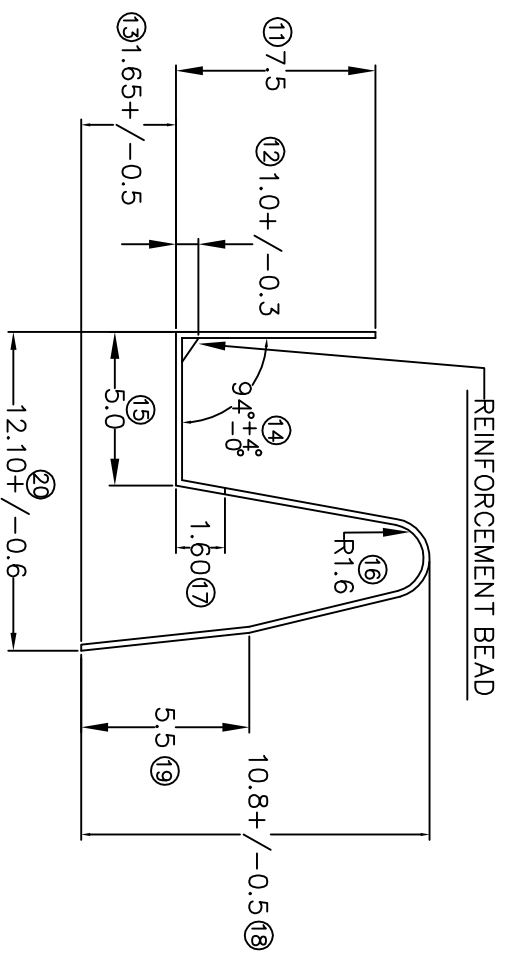
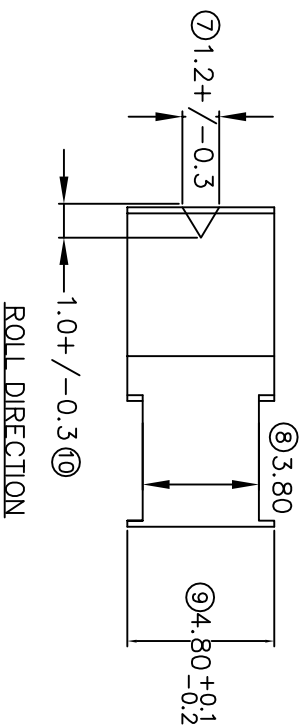

FOR REFERENCE ONLY

- 3) TEMPERATURE RANGE -40°C TO +120°C.
- 2) VOLTAGE-MAX [VOLTS] PER WIRE SPECIFICATION.
- 1) PACKING QTY : 6000 PCS/BAG.

SPECIFICATION :

MATERIAL: t0.15 TITANIUM COPPER C1990	DIMENSIONS : MM TOLERANCE UNLESS OTHERWISE SPECIFIED: X.XXX +/-0.05 X.XX +/-0.10 X.X +/-0.20 X +/-0.50	DWN: KS YEW CHK: HY LIM APVD: CHUANG SCALE : FREE DRAWING NO: A1402	TREATMENT SELECTIVE PART NUMBER MP-180
EFFECTIVE DATE : 27/9/07		PART NAME: EPJ Terminals & Connectors Elamp Precision Industry(M) Sdn.Bhd.	
REVISION: 04		SPRING CONTACT TERMINALS APPLICABLE (1) TERMINALS (2) HOUSING (1) - (2) -	
SHEET OF : 1 / 1		DRAWING NO: A1402	