

# SPECIFICATION DRAWING

MASTER COPY

ITEM NO	MATERIAL	TREATMENT	QTY/REEL	REEL/CARTON	MATCHING PART(S)
SAN20-2T	t0.2 BRASS (C2680)	PRE-TIN PLATED	10000 PCS	8	TERMINAL-N/A HOUSING-SAN20HP

SYMBOL	DESCRIPTION
○	DIMENSION INSPECTED DURING SETUP AND OUTGOING.
□	DIMENSION INSPECTED HOURLY.
SPC	STATISTICALLY CONTROLLED DIMENSION.
△	JIG USED DURING INSPECTION.

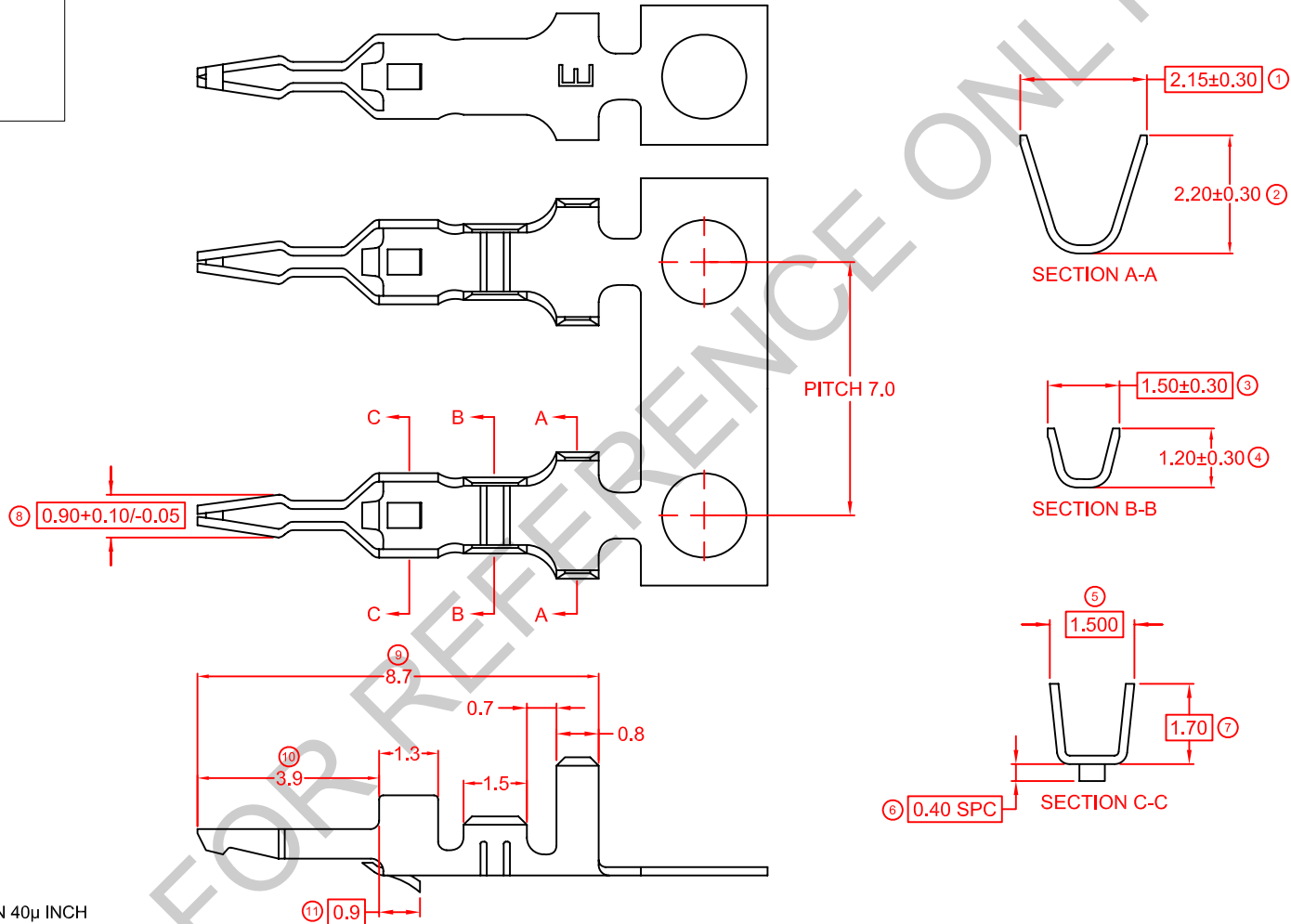
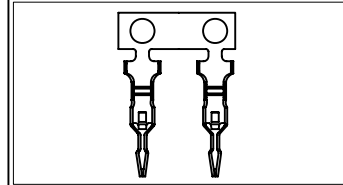

**REMARKS:**

- a) PLATING THICKNESS MIN 40μ INCH
- b) SUGGESTED WIRE INSULATION (O.D): 1.3MM
- c) SUGGESTED WIRE RANGE: 0.15~0.06MM<sup>2</sup> (AWG 24~28)
- d) MATCHING WITH PC BOARD Ø0.8MM±0.05MM THICKNESS 1.6MM/1.2MM

				REVISION: 07	GENERAL TOLERANCE UNLESS SPECIFIED: X.XXX ±0.05 X.XX ±0.10 X.X ±0.20 X ±0.50	PREPARE BY: KS YEW	Elamp Precision Industry(M) Sdn.Bhd.
						REVIEWED BY: CH ANG	
07	15/9/11	TYPO PITCH 9.0 TO PITCH 7.0	11-09-45	⊕		APPROVED BY: CY CHUANG	ITEM NO: SAN20-2T
06	8/9/11	UPDATE TO NEW FORMAT	-		SHEET OF: 1 / 1	EFFECTIVE DATE: 15/9/11	SCALE : FREE UNIT : MM
REV.	DATE	AMENDMENT	ECR NO:				